

Side emitting

SAFETY & WARNINGS

READ AND FOLLOW ALL SAFETY INSTRUCTIONS

1. Install in accordance with national and local electrical code regulations.
2. This product is intended to be installed and serviced by a qualified, licensed electrician.
3. Do not modify or disassemble this product beyond instructions or the warranty will be void.
4. Do not use if there is any damage to the fixture or wiring. Inspect periodically.
5. Do not submerge Strip Light in liquids or use the product in the vicinity of standing water or other liquids.
6. Do not install near areas with exposure to chlorinated water. (Salt water environments are approved)
7. Do not install in direct sunlight or damage to the LED phosphor will occur.
8. Do not attempt to fix this product in the field.
9. Failure to follow safety warnings, and installation instructions will void the warranty for this product.

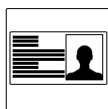

QUICK SPECS / MODELS

Input	24VDC Constant Voltage
Power	4.4/ft
Ambient Temp †	-4° - 122°F (-20° - 50°C)
Environment	Indoor/Outdoor/IP65

† Do not install product in environment outside listed temperature.

***NOT FOR USE IN SUBMERSIBLE APPLICATIONS, OR WITHIN 5 FEET OF A SWIMMING POOL.**

NEON BLAZE™ RGB 24V LED Strip Light

INSTALLATION GUIDE

REQUIRED TOOLS

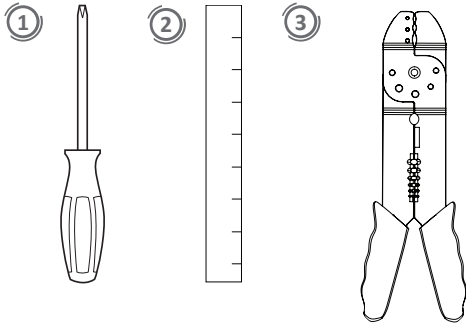

1. Phillips-head Screwdriver (Recommended)
2. Ruler (Recommended)
3. Wire Stripper (Recommended)

HANDLE PRODUCT WITH CARE!

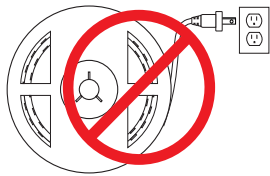

DO NOT POWER STRIP LIGHT WHILE ATTACHED TO SPOOL OR TIGHTLY COILED.

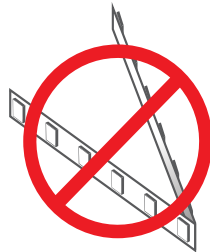

DO NOT FOLD, CREASE, OR TWIST LED STRIP LIGHT.

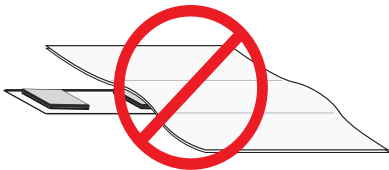

DO NOT COVER STRIP LIGHT WITH ANY MATERIALS.

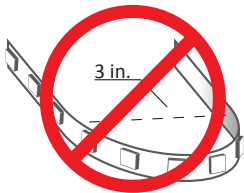

DO NOT BEND LED STRIP LIGHT TO A DIAMETER LESS THAN 3 INCHES.

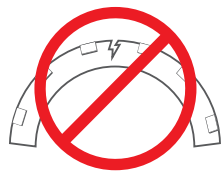

DO NOT BEND LED STRIP LIGHT ON A VERTICAL PLANE.

INSTALLATION

1 TURN POWER OFF AT CIRCUIT BREAKER



SHOCK HAZARD! May result in serious injury or death.

Turn power OFF at circuit breaker prior to installation.

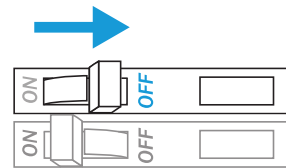

2 CUT NEON BLAZE™ RGB LED STRIP LIGHT TO LENGTH

Ensure to cut the Strip Light at the designated cut points only. Cutting anywhere else will cause damage to the Strip Light.

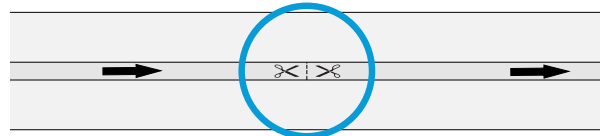

3 CREATE END CAP TERMINATION

Attach end cap to terminated ends of NEON BLAZE™ RGB LED Strip Light

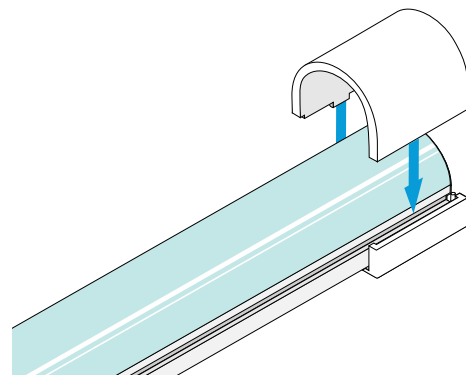

NEON BLAZE™ RGB 24V LED Strip Light

INSTALLATION GUIDE

INSTALLATION (CONT.)

4 MOUNT BLAZE™ NEON RGB LED STRIP LIGHT

Option A: Bottom U-Clips

- a) Screw bottom u-clips to surface.

Note: It is recommended to use two bottom u-clips for every foot of NEON BLAZE™ RGB LED Strip Light.

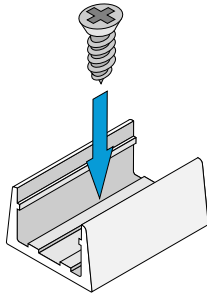

Insert NEON BLAZE™ RGB LED Strip Light into bottom u-clip.

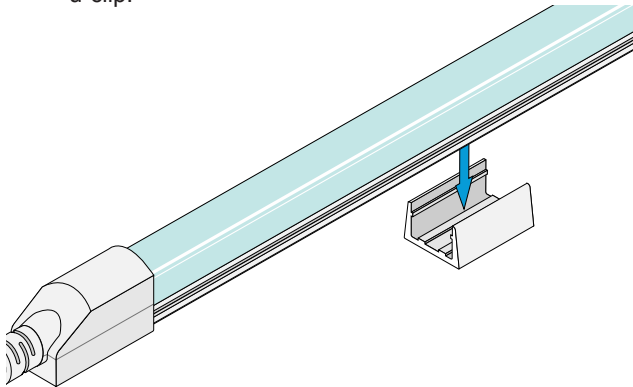

Option B: Top U-Clips

- b) Place NEON BLAZE™ RGB LED Strip Light on surface, then place clear top u-clip over Strip Light.

Note: It is recommended to use two clear top u-clips for every foot of NEON BLAZE™ RGB LED Strip Light.

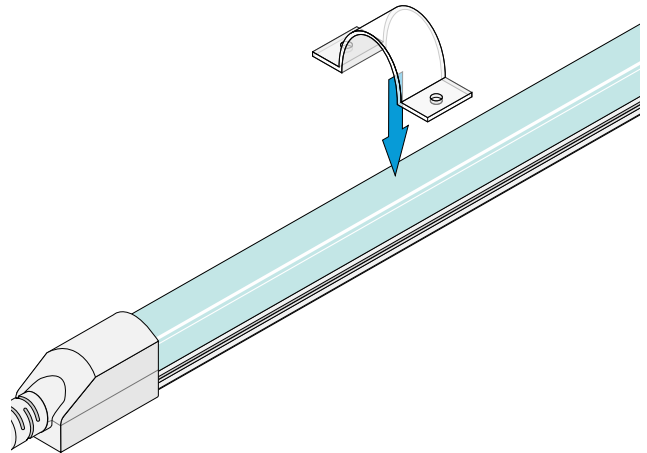

Screw top u-clip to surface.

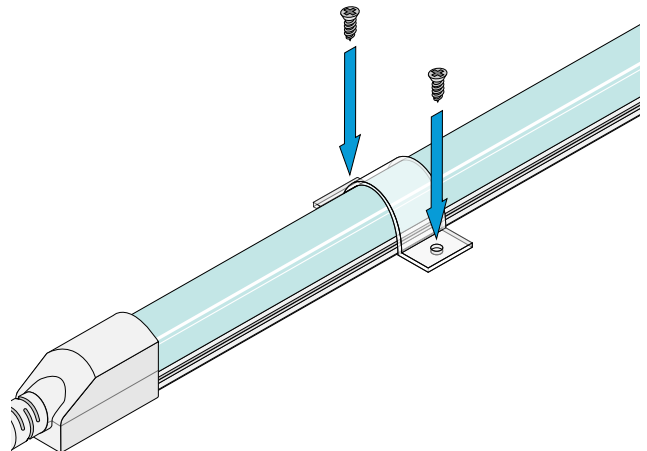

NEON BLAZE™ RGB 24V LED Strip Light

INSTALLATION GUIDE

INSTALLATION (CONT.)

NEON BLAZE™ RGB LED Strip Light may be bent to resemble neon lighting. Examples below:

Side emitting NEON BLAZE™ RGB LED Strip Light may be bent "Left and Right" on the horizontal axis of the Strip Light.

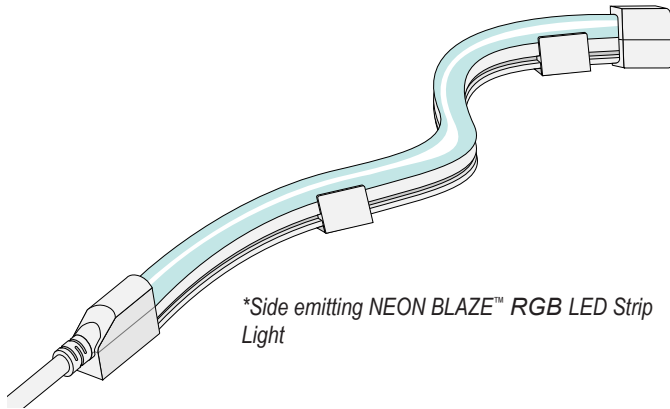

5 CONNECT TO 96" EXTENSION CABLE

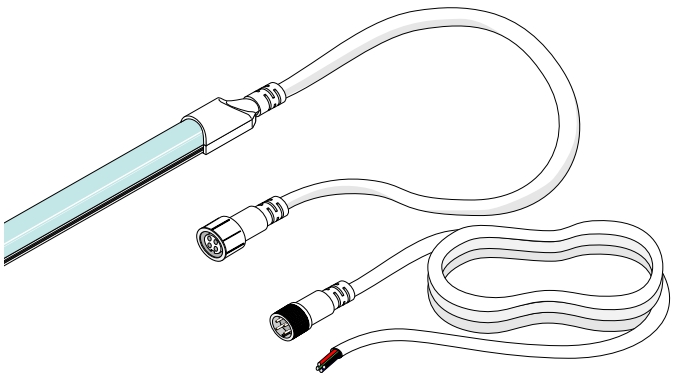

NEON BLAZE™ RGB Extension Cable.

Screw connector cap onto extension cable securely.

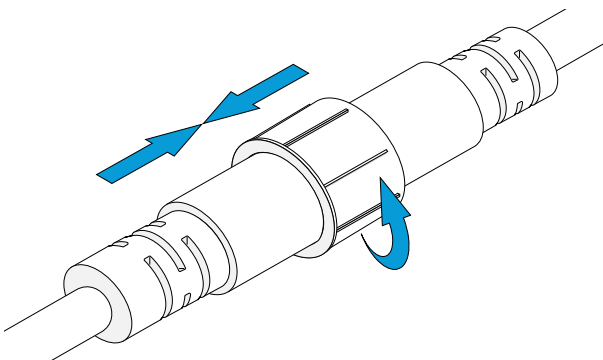

6 ATTACH DRIVER AND LIGHTING CONTROL.

Verify a compatible driver is installed. Utilize applicable wiring when installing outdoors. (Use of wet location-rated junction box recommended)

7 TURN POWER ON AT CIRCUIT BREAKER

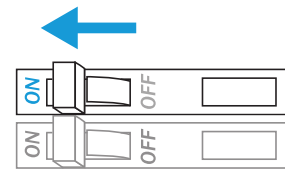

TROUBLESHOOTING

Shift in brightness	<ul style="list-style-type: none">• Ensure an appropriate gauge of wire is installed between strip light and LED driver. See VOLTAGE DROP CHARTS.
Some LEDs are not functional	<ul style="list-style-type: none">• Ensure strip light has not been bent excessively, which could damage circuitry.• Ensure strip light has not been submerged in any liquid for any amount of time.
Lights are flickering	<ul style="list-style-type: none">• Ensure a compatible driver and/or dimming control is installed. Check for loose connections.
Lights are turning on/off repeatedly	<ul style="list-style-type: none">• Ensure driver is not overloaded. An overloaded driver will trip the internal auto-reset (of driver) repeatedly, turning the system on/off.

TOOLS & RESOURCES

NEON BLAZE™ RGB SPECIFICATION SHEET

For full specifications.

NEON BLAZE™ RGB 24V LED Strip Light

INSTALLATION GUIDE

SYSTEM DIAGRAMS

The following diagrams are provided as example system designs. For information regarding larger systems or systems not pictured below, please see our web page or contact technical support. Always review each component installation guide for detailed and up-to-date wiring instructions. Install in accordance with national and local electrical codes.

RGB/RGBW COLOR CONTROL SYSTEMS

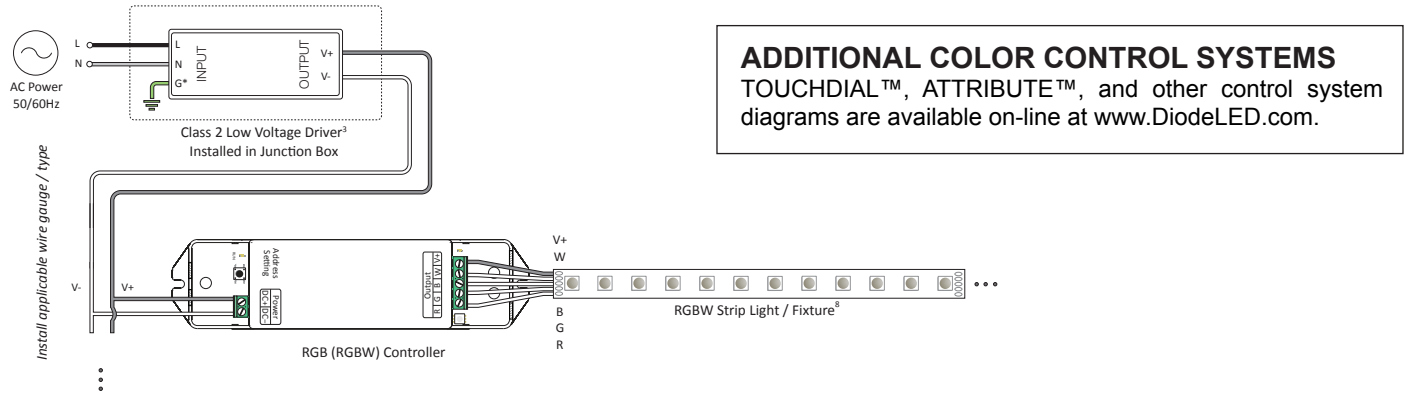

DMX CONTROL SYSTEM

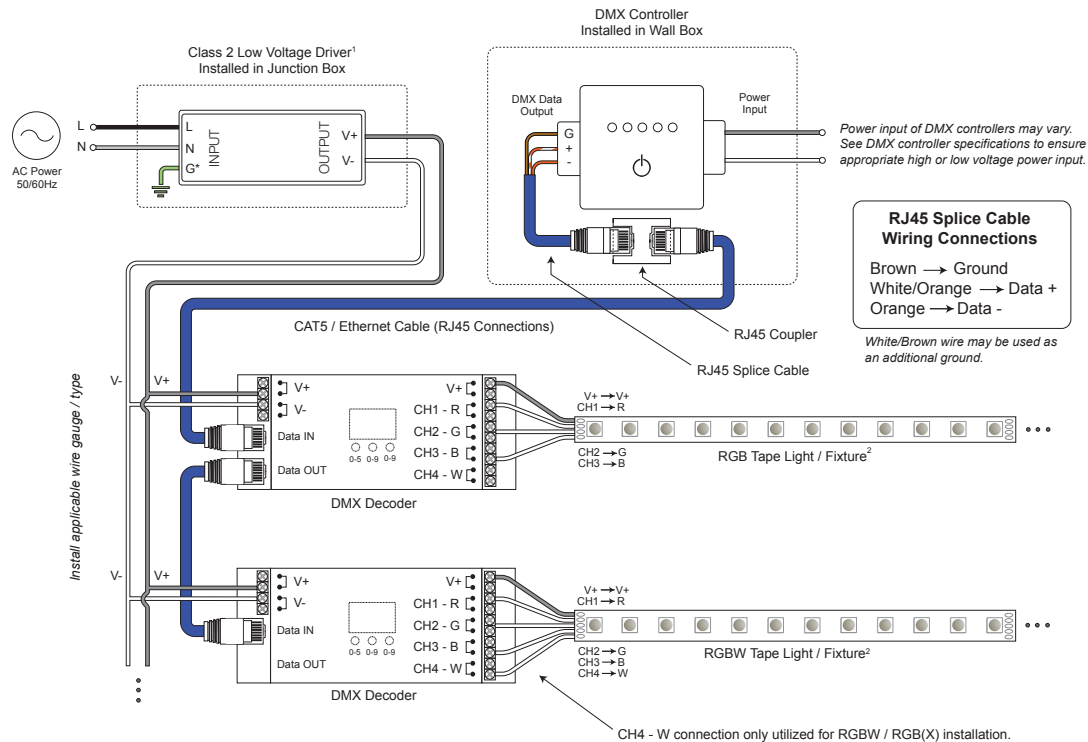

1. Driver may not require a fault ground connection. Refer to driver specifications for additional information.
2. See fixture specifications for maximum series run limits.

NEON BLAZE™ RGB 24V LED Strip Light

INSTALLATION GUIDE

VOLTAGE DROP CHARTS

For best performance and lumen output, ensure proper wire gauge is installed to compensate for voltage drop of low voltage circuits.

Example: 24V Voltage Drop & Wire Length Distance Chart

Wire Gauge	10 W .42 A	20 W .83 A	30 W 1.3 A	40 W 1.7 A	50 W 2.1 A	60 W 2.5 A
18 AWG	134 ft.	68 ft.	45 ft.	33 ft.	27 ft.	22 ft.
16 AWG	215 ft.	109 ft.	72 ft.	54 ft.	43 ft.	36 ft.
14 AWG	345 ft.	174 ft.	115 ft.	86 ft.	69 ft.	57 ft.
12 AWG	539 ft.	272 ft.	181 ft.	135 ft.	108 ft.	90 ft.
10 AWG	784 ft.	397 ft.	263 ft.	197 ft.	158 ft.	131 ft.

① Determine load size. Let's assume load is 55 W. Round up to nearest load.

② Determine distance from driver to load. Let's assume the distance is 90 ft.

③ It is recommended to install 12 AWG to eliminate excess voltage drop.

24V Voltage Drop & Wire Length Distance Chart

Wire Gauge	10 W .42 A	20 W .83 A	30 W 1.3 A	40 W 1.7 A	50 W 2.1 A	60 W 2.5 A	70 W 2.9 A	80 W 3.3 A	100 W 4.2 A
18 AWG	134 ft.	68 ft.	45 ft.	33 ft.	27 ft.	22 ft.	19 ft.	17 ft.	14 ft.
16 AWG	215 ft.	109 ft.	72 ft.	54 ft.	43 ft.	36 ft.	31 ft.	27 ft.	22 ft.
14 AWG	345 ft.	174 ft.	115 ft.	86 ft.	69 ft.	57 ft.	49 ft.	43 ft.	36 ft.
12 AWG	539 ft.	272 ft.	181 ft.	135 ft.	108 ft.	90 ft.	77 ft.	68 ft.	56 ft.
10 AWG	784 ft.	397 ft.	263 ft.	197 ft.	158 ft.	131 ft.	112 ft.	98 ft.	82 ft.



Toll Free: 877.817.6028 | Fax: 415.592.1596 | www.DiodeLED.com | info@DiodeLED.com
 © 2019 Elemental LED Inc. All rights reserved. Specifications are subject to change without notice.